



MODEL PHOTO: ACT 1-3
NOT TO SCALE



MODEL PHOTO: ACT 4
NOT TO SCALE

PRODUCTION TEAM:

DIRECTOR
KATIE BROOK
SCENIC DESIGNER
CECILIA SHIN
LIGHTING DESIGNER
XUEWEI HU
COSTUME DESIGNER
EMILY MARSHBURN
SOUND DESIGNER
EMILY BRUNNER
PRODUCTION MANAGER
MELISSA LUBINA
TECHNICAL DIRECTOR / JOB LEAD
OWEN SAHNOW

DATE: 02/03/2023

SCALE: 3/8" = 1'- 0"

REVISION NO: V5

DRAWN BY: C.S.

The designer is responsible for the visual aspects of the production only, and the specification of the designer's designs relate solely to the appearance of the design and not to matters of safety. The designer agrees to make prompt correcting alterations to any specifications found to be incompatible with proper safety precautions.

**3/8" GROUND PLAN
ACT 1-3**

PLATE NO.

1

OF 8

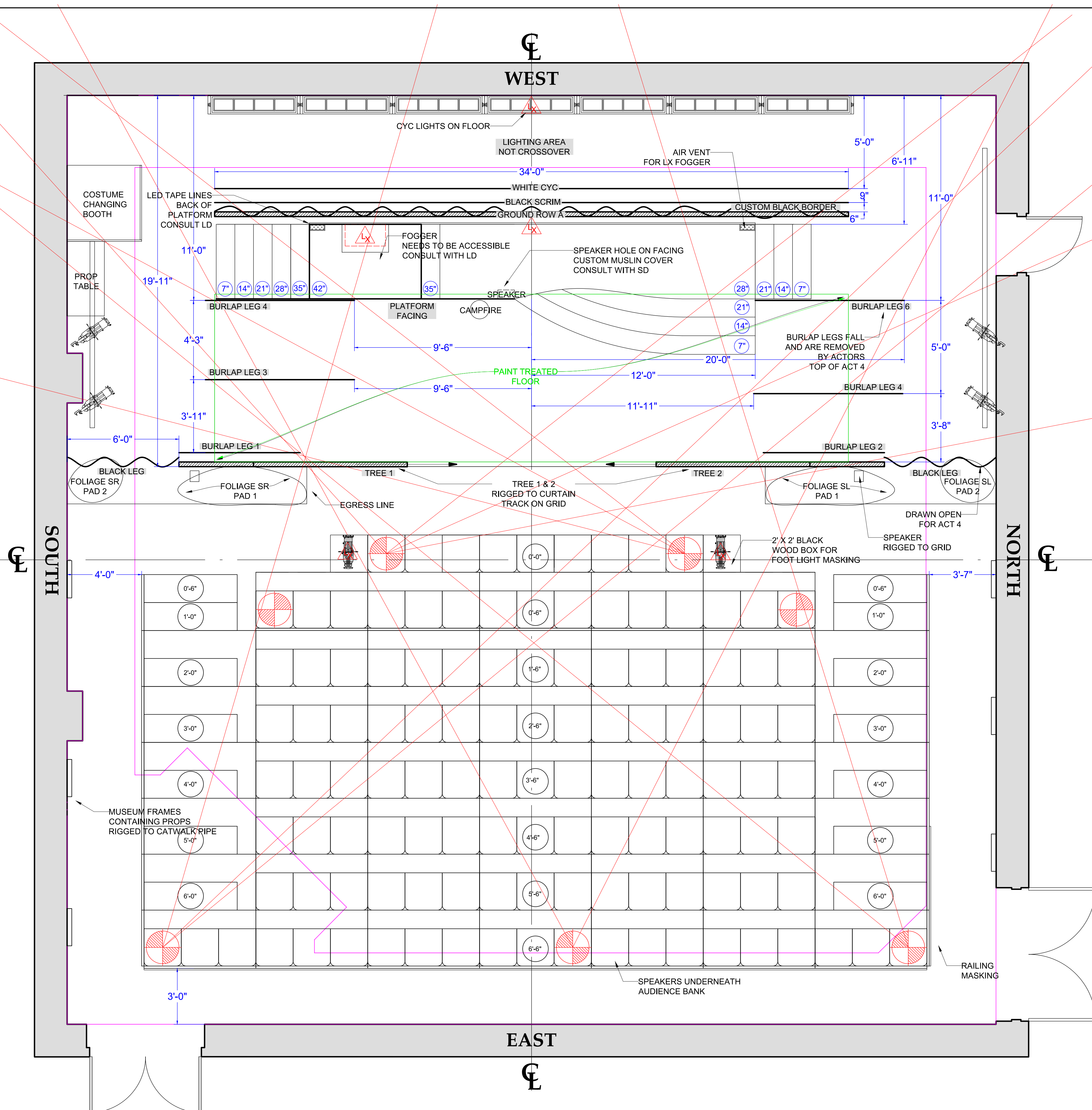

- NOTES:**
- BURLAP LEGS 1-6 FALL AND ARE REMOVED BY ACTORS TOP OF ACT 4
 - OPEN FLAME ON SET FIREPROOFING OF SCENERY REQUIRED
 - LED TAPE LINES THE BACK OF THE PLATFORM
 - BLACK LEGS ARE DRAWN OPEN FOR ACT 4
 - MONITORS FOR STAGE MANAGEMENT REQUIRED
 - FLOOR TREATMENT AREA: 34'-0" x 9'-0"
 - FOLIAGE PADS CAN BE WALKED ON
 - CAMPFIRE IS A PROP BROUGHT ON STAGE

- ELEMENTS LIST:**
- CUSTOM BLACK BORDER
 - WHITE CYC
 - BLACK SCRIM
 - 2X BLACK LEGS
 - BURLAP LEGS 1, 2, 3, 4, 5, 6
 - GROUND ROW A
 - PLATFORM FACING
 - PLATFORM
 - TREE 1 AND 2 (RIGGED TO CURTAIN TRACK ON GRID)
 - FOLIAGE PADS SR, SL
 - SEATING BANK RAILING MASKING
 - 2X CHANGING BOOTH PANELS 8' X 4'
 - 6X MUSEUM FRAMES RIGGED



MODEL PHOTO: ACT 1-3
NOT TO SCALE



MODEL PHOTO: ACT 4
NOT TO SCALE

PRODUCTION TEAM:

DIRECTOR
KATIE BROOK
SCENIC DESIGNER
CECILIA SHIN
LIGHTING DESIGNER
XUEWEI HU
COSTUME DESIGNER
EMILY MARSHBURN
SOUND DESIGNER
EMILY BRUNNER
PRODUCTION MANAGER
MELISSA LUBINA
TECHNICAL DIRECTOR / JOB LEAD
OWEN SAHNOW

DATE: 02/03/2023

SCALE: 3/8" = 1'- 0"

REVISION NO: V5

DRAWN BY: C.S.

The designer is responsible for the visual aspects of the production only, and the specification of the designer's designs relate solely to the appearance of the design and not to matters of safety. The designer agrees to make prompt correcting alterations to any specifications found to be incompatible with proper safety precautions.

**3/8" GROUND PLAN
ACT 4**

PLATE NO.

2

OF 8

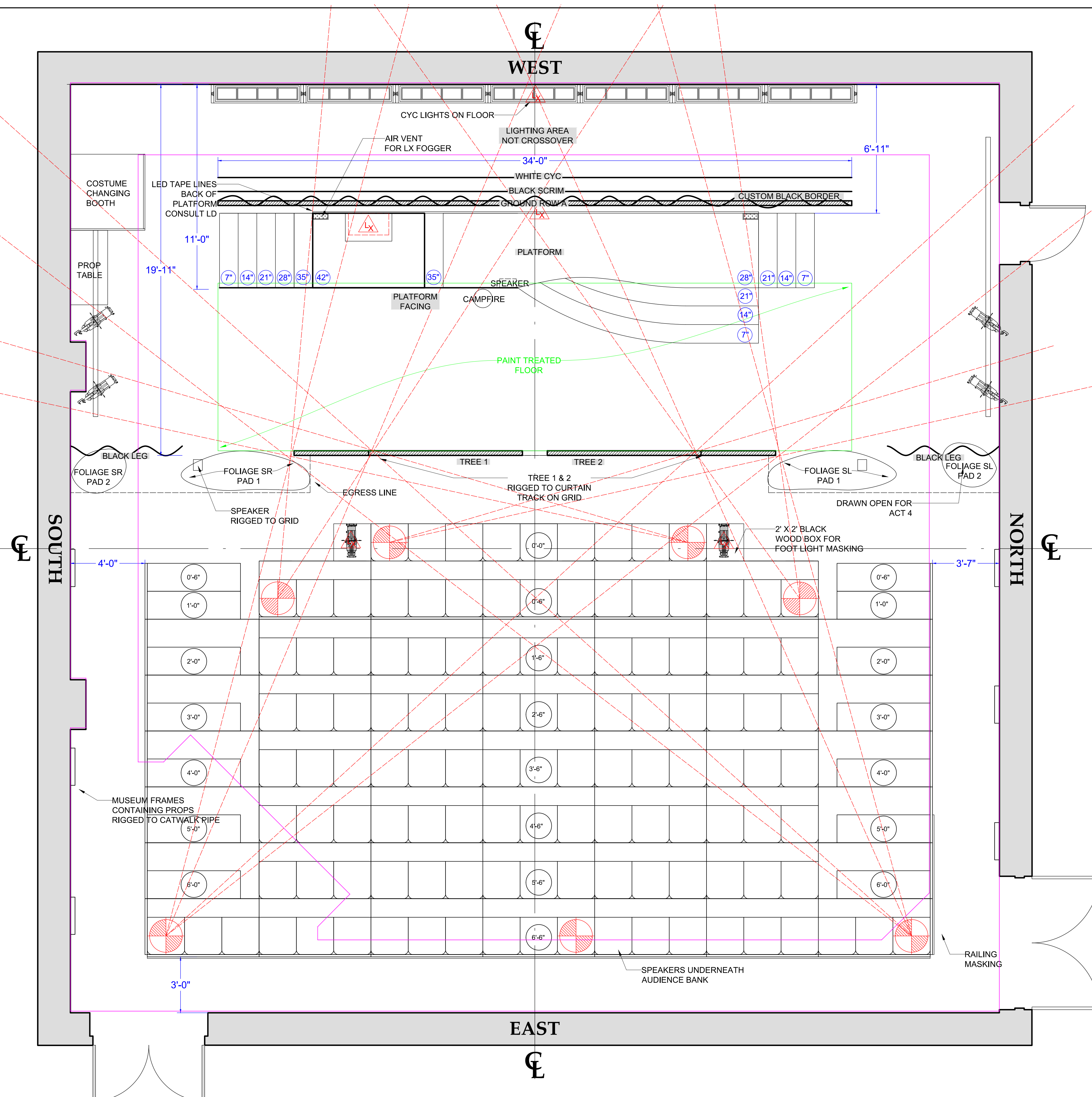

- NOTES:**
- BURLAP LEGS 1-6 FALL AND ARE REMOVED BY ACTORS TOP OF ACT 4
 - OPEN FLAME ON SET FIREPROOFING OF SCENERY REQUIRED
 - LED TAPE LINES THE BACK OF THE PLATFORM
 - BLACK LEGS ARE DRAWN OPEN FOR ACT 4
 - MONITORS FOR STAGE MANAGEMENT REQUIRED
 - FLOOR TREATMENT AREA: 34'-0" x 8'-5"
 - FOLIAGE PADS CAN BE WALKED ON
 - CAMPFIRE IS A PROP BROUGHT ON STAGE

- ELEMENTS LIST:**
- CUSTOM BLACK BORDER
 - WHITE CYC
 - BLACK SCRIM
 - 2X BLACK LEGS
 - BURLAP LEGS 1, 2, 3, 4, 5, 6
 - GROUND ROW A
 - PLATFORM FACING
 - PLATFORM
 - TREE 1 AND 2 (RIGGED TO CURTAIN TRACK ON GRID)
 - FOLIAGE PADS SR, SL
 - SEATING BANK RAILING MASKING
 - 2X CHANGING BOOTH PANELS 8' X 4'
 - 6X MUSEUM FRAMES RIGGED

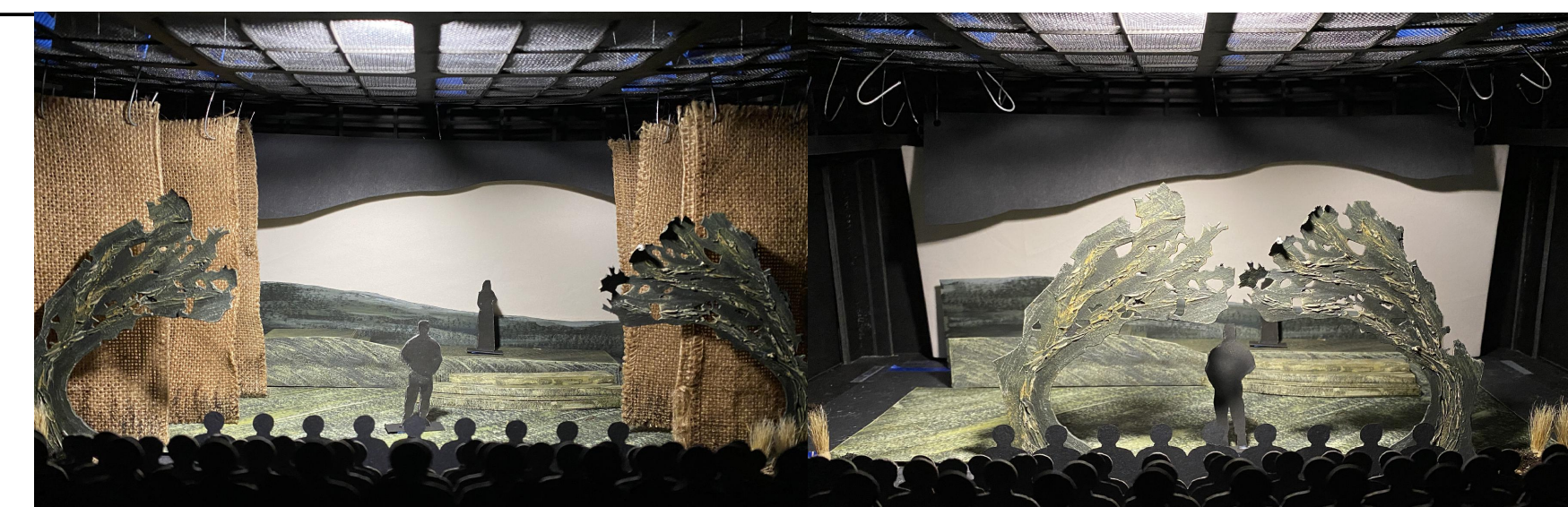

MODEL PHOTO: ACT 1-3
NOT TO SCALE

MODEL PHOTO: ACT 4
NOT TO SCALE

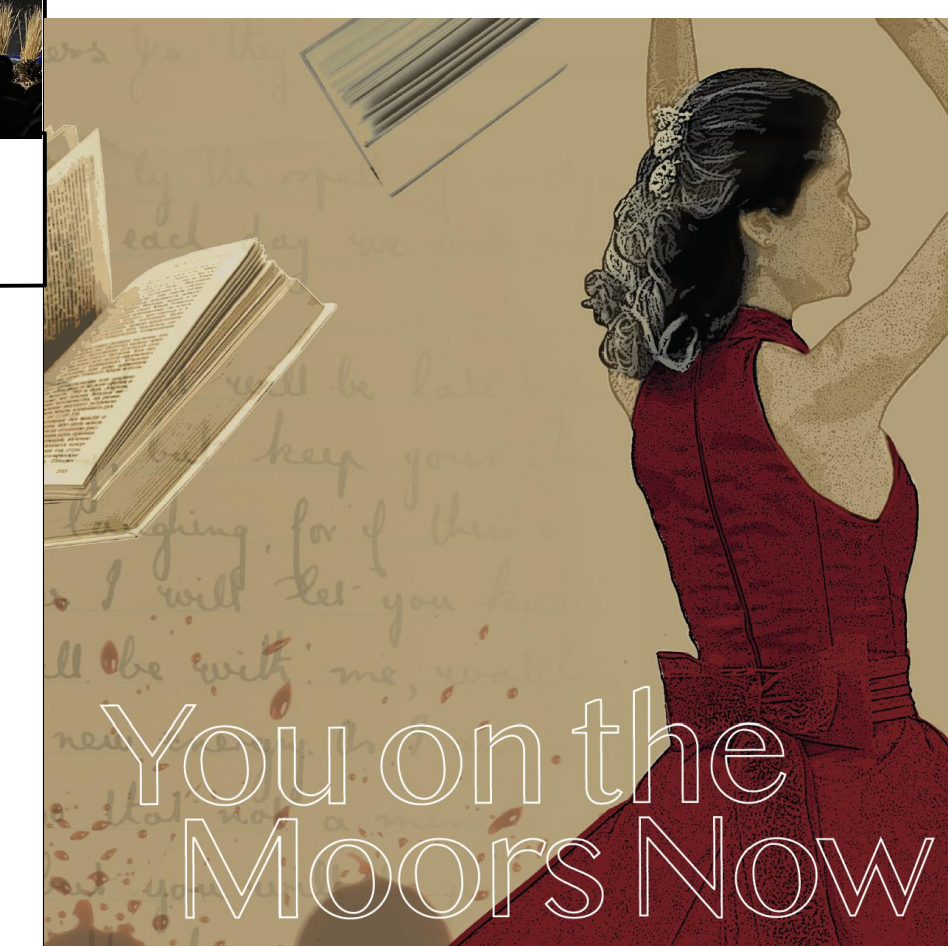

You on the
Moors Now

PRODUCTION TEAM:

- DIRECTOR
KATIE BROOK
- SCENIC DESIGNER
CECILIA SHIN
- LIGHTING DESIGNER
XUEWEI HU
- COSTUME DESIGNER
EMILY MARSHBURN
- SOUND DESIGNER
EMILY BRUNNER
- PRODUCTION MANAGER
MELISSA LUBINA
- TECHNICAL DIRECTOR / JOB LEAD
OWEN SAHNOW

DATE: 02/03/2023

SCALE: 1/2" = 1'- 0"

REVISION NO: V5

DRAWN BY: C.S.

The designer is responsible for the visual aspects of the production only, and the specification of the designer's designs relate solely to the appearance of the design and not to matters of safety. The designer agrees to make prompt correcting alterations to any specifications found to be incompatible with proper safety precautions.

1/2" FRONT VIEW ACT 1-3

PLATE NO.

3A

OF 8

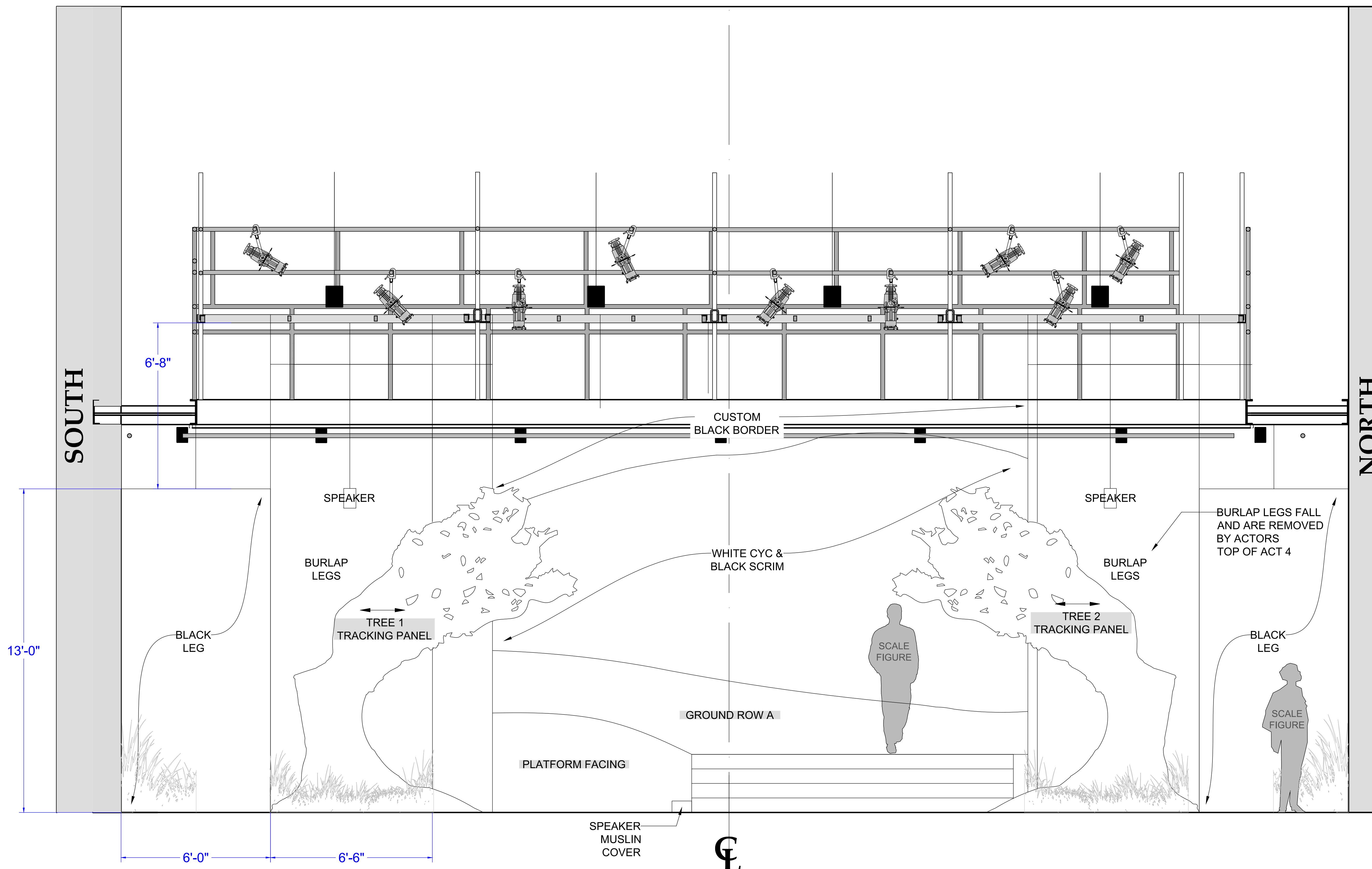

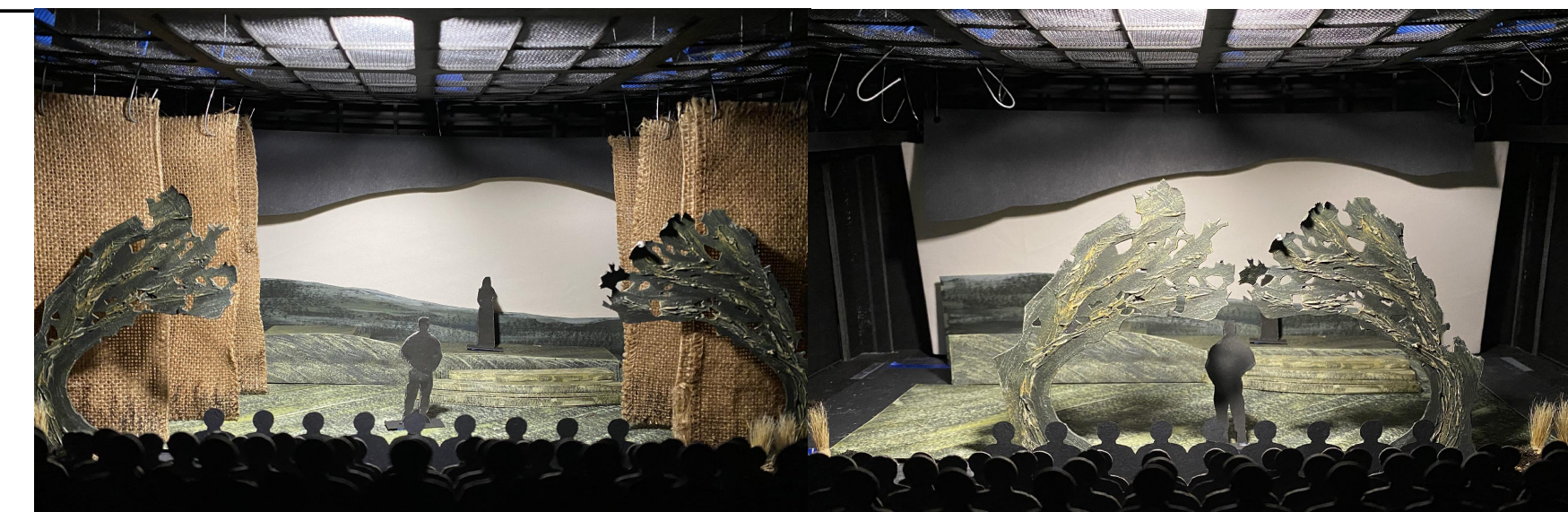

MODEL PHOTO: ACT 1-3
NOT TO SCALE

MODEL PHOTO: ACT 4
NOT TO SCALE

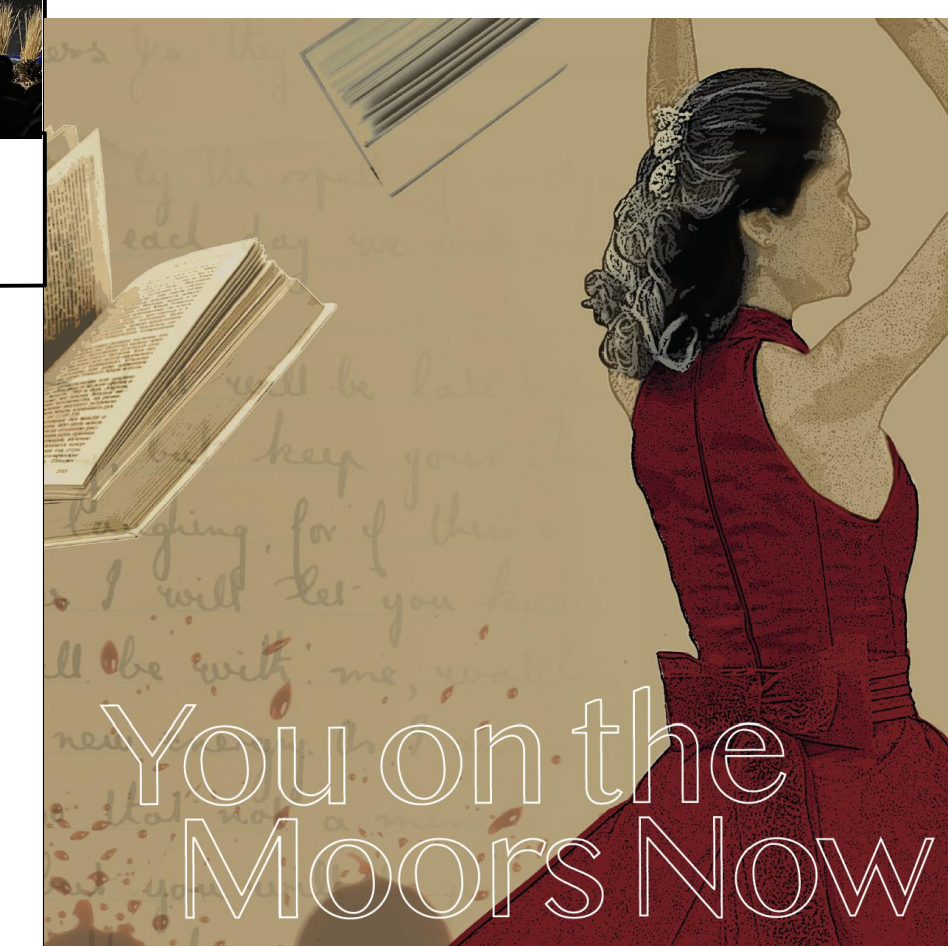

You on the
Moors Now

PRODUCTION TEAM:

- DIRECTOR
KATIE BROOK
- SCENIC DESIGNER
CECILIA SHIN
- LIGHTING DESIGNER
XUEWEI HU
- COSTUME DESIGNER
EMILY MARSHBURN
- SOUND DESIGNER
EMILY BRUNNER
- PRODUCTION MANAGER
MELISSA LUBINA
- TECHNICAL DIRECTOR / JOB LEAD
OWEN SAHNOW

DATE: 02/03/2023

SCALE: 1/2" = 1'- 0"

REVISION NO: V5

DRAWN BY: C.S.

The designer is responsible for the visual aspects of the production only, and the specification of the designer's designs relate solely to the appearance of the design and not to matters of safety. The designer agrees to make prompt correcting alterations to any specifications found to be incompatible with proper safety precautions.

1/2" ELEVATION ACT 1-3

PLATE NO.

3B

OF 8

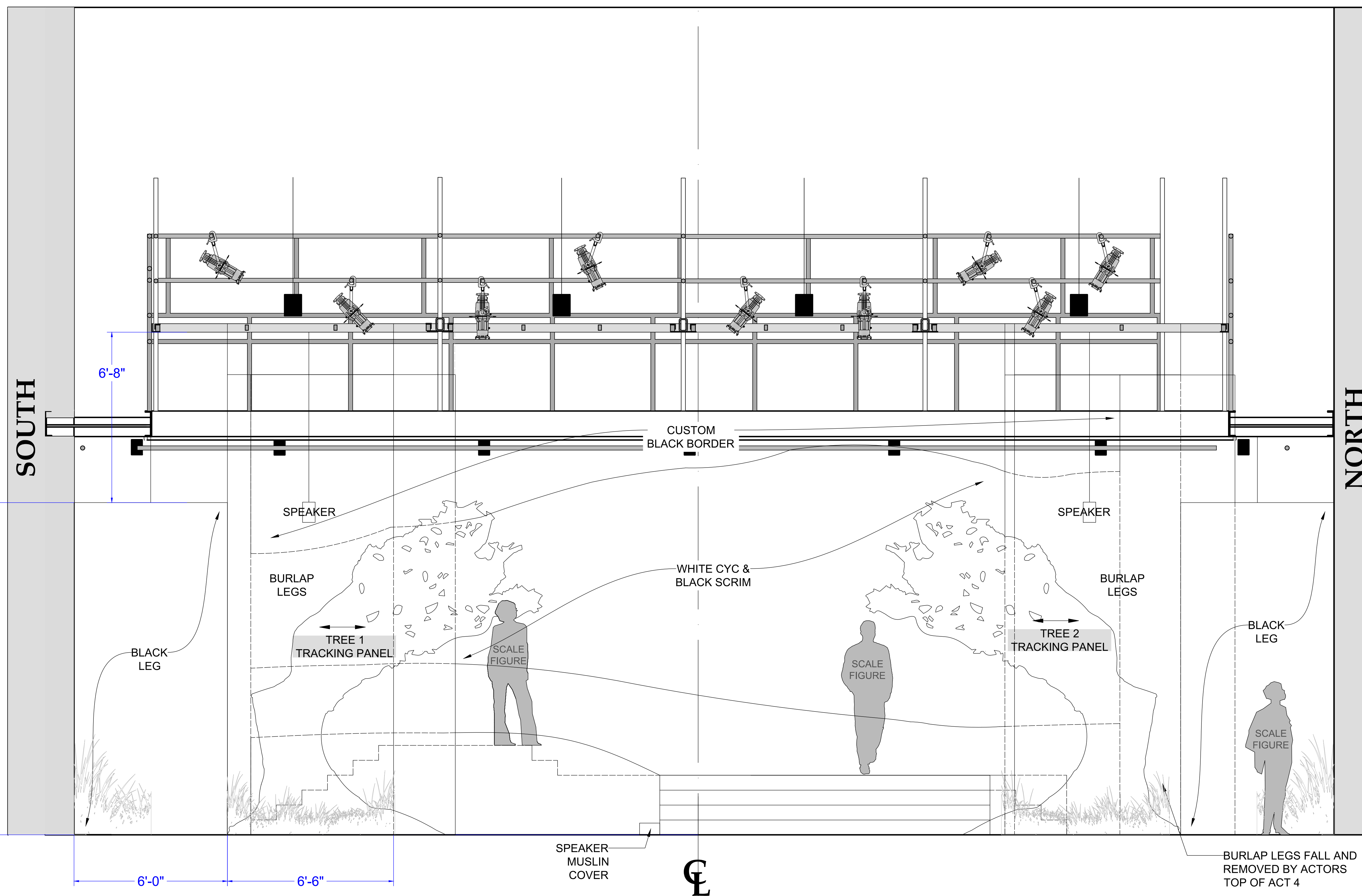

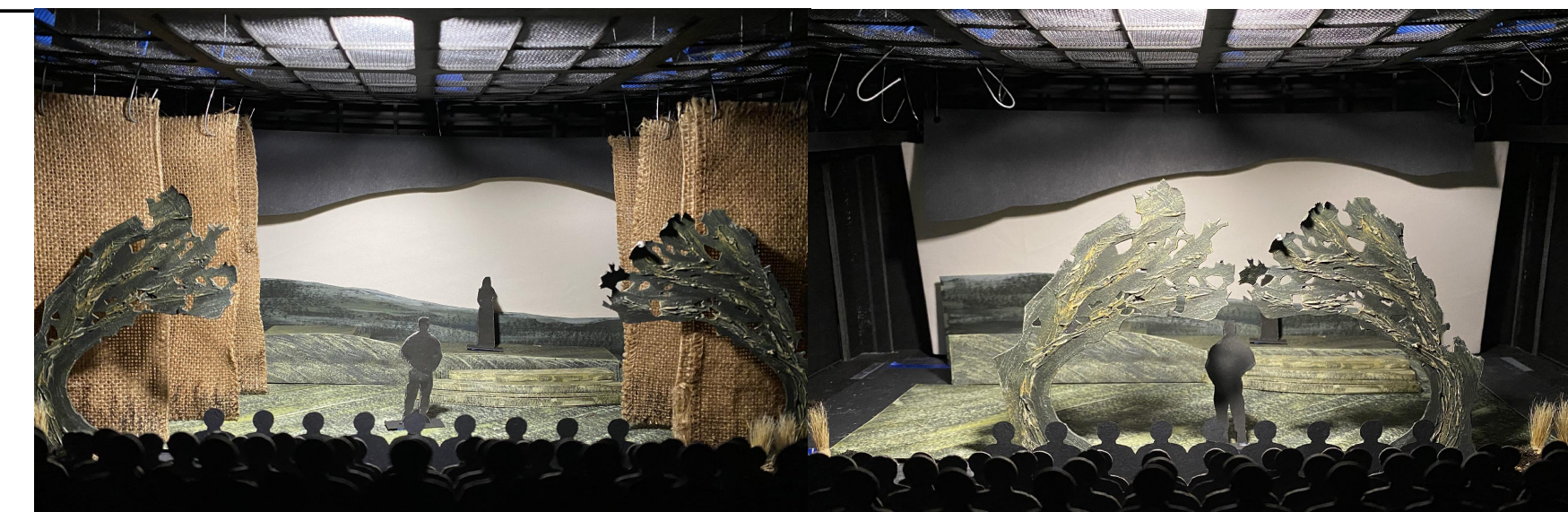

MODEL PHOTO: ACT 1-3
NOT TO SCALE

MODEL PHOTO: ACT 4
NOT TO SCALE

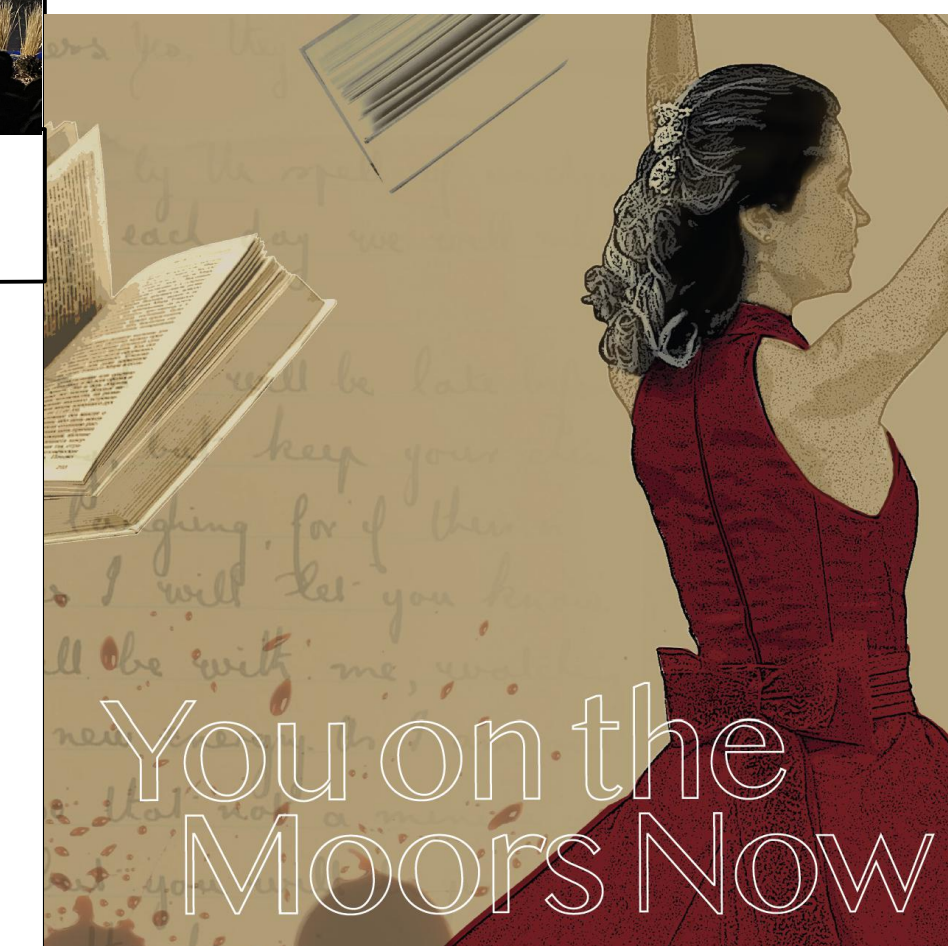

PRODUCTION TEAM:

- DIRECTOR
KATIE BROOK
- SCENIC DESIGNER
CECILIA SHIN
- LIGHTING DESIGNER
XUEWEI HU
- COSTUME DESIGNER
EMILY MARSHBURN
- SOUND DESIGNER
EMILY BRUNNER
- PRODUCTION MANAGER
MELISSA LUBINA
- TECHNICAL DIRECTOR / JOB LEAD
OWEN SAHNOW

DATE: 02/03/2023

SCALE: 1/2" = 1'- 0"

REVISION NO: V5

DRAWN BY: C.S.

The designer is responsible for the visual aspects of the production only, and the specification of the designer's designs relate solely to the appearance of the design and not to matters of safety. The designer agrees to make prompt correcting alterations to any specifications found to be incompatible with proper safety precautions.

1/2" ELEVATION ACT 4

PLATE NO.

4

OF 8

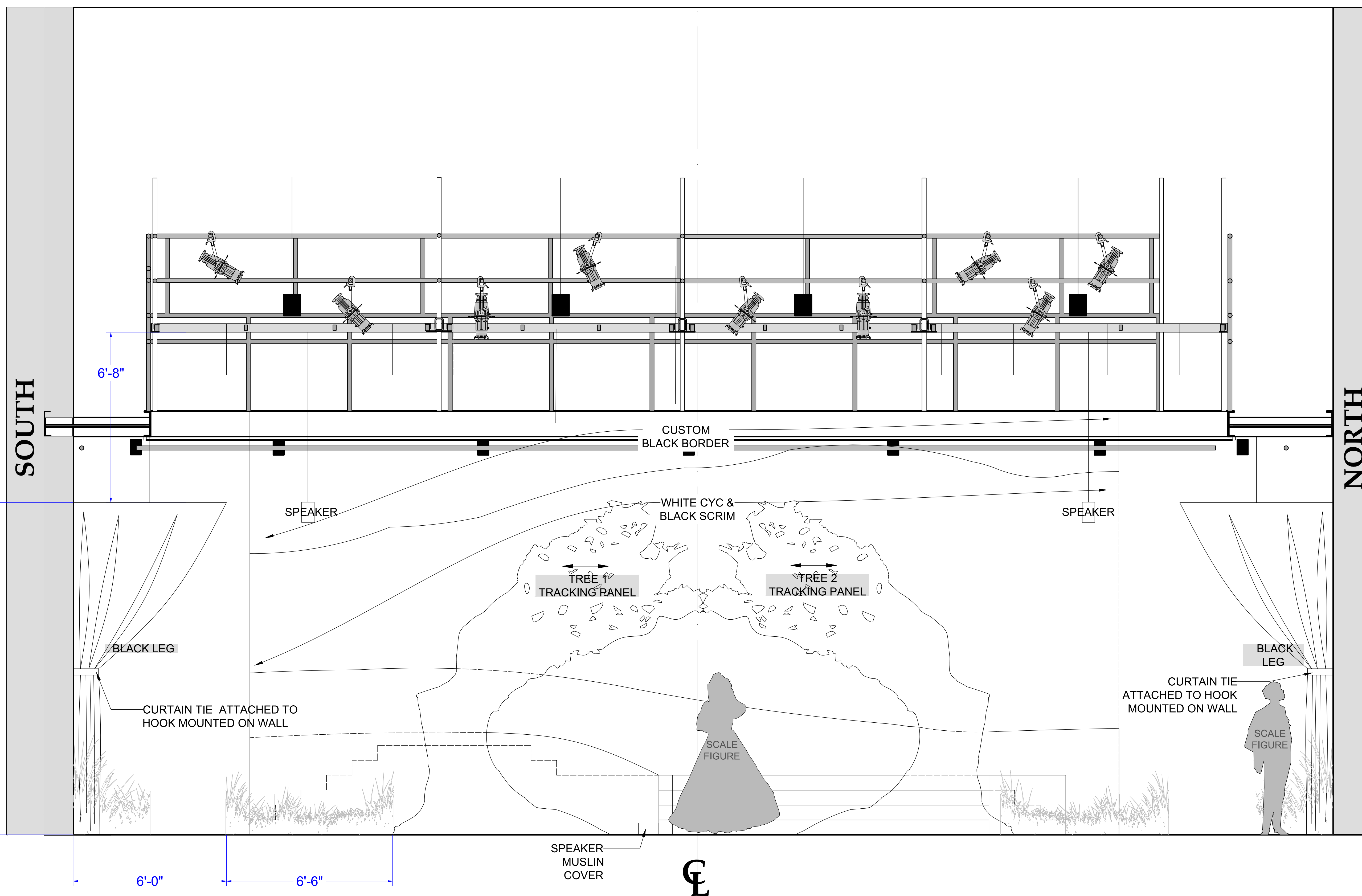

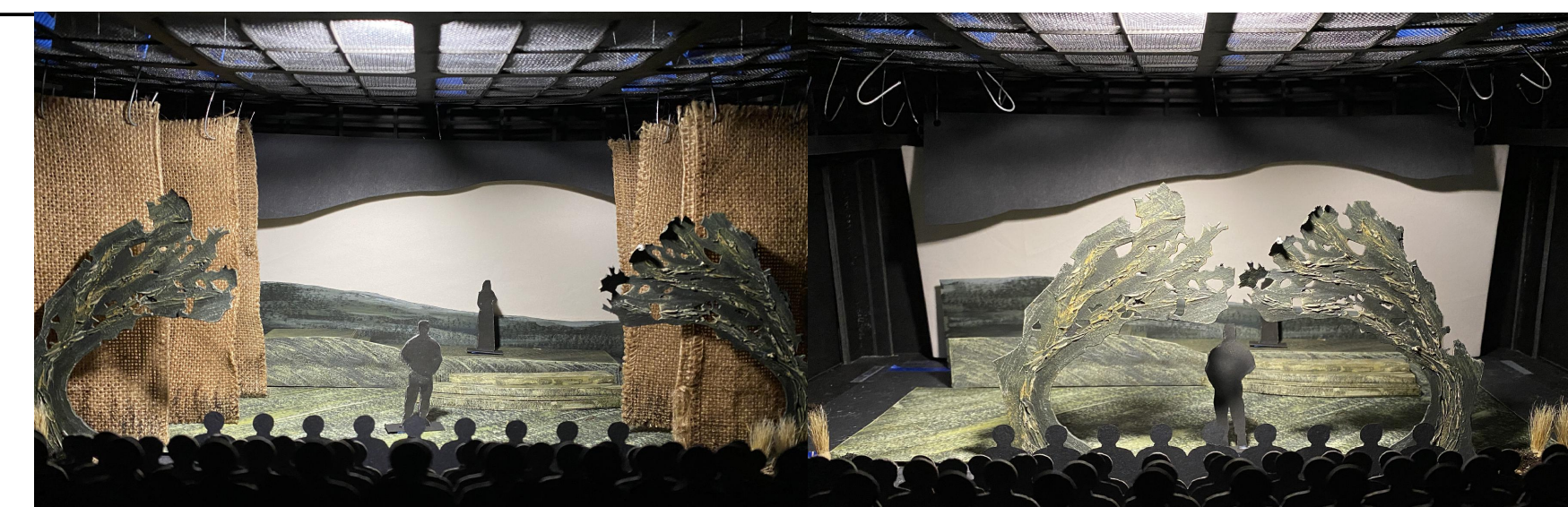

MODEL PHOTO: ACT 1-3
NOT TO SCALE

MODEL PHOTO: ACT 4
NOT TO SCALE

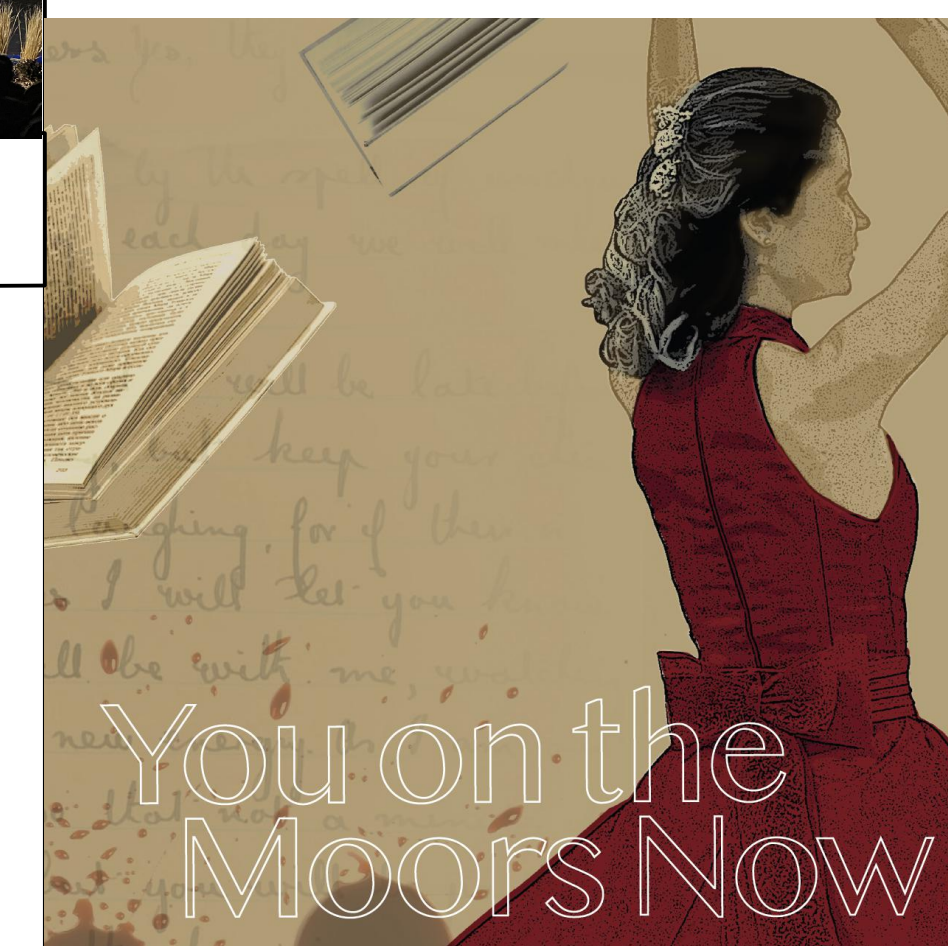

You on the
Moors Now

PRODUCTION TEAM:

DIRECTOR
KATIE BROOK
SCENIC DESIGNER
CECILIA SHIN
LIGHTING DESIGNER
XUEWEI HU
COSTUME DESIGNER
EMILY MARSHBURN
SOUND DESIGNER
EMILY BRUNNER
PRODUCTION MANAGER
MELISSA LUBINA
TECHNICAL DIRECTOR / JOB LEAD
OWEN SAHNOW

DATE: 02/03/2023

SCALE: 1/2" = 1'- 0"

REVISION NO: V5

DRAWN BY: C.S.

The designer is responsible for the visual aspects of the production only, and the specification of the designer's designs relate solely to the appearance of the design and not to matters of safety. The designer agrees to make prompt correcting alterations to any specifications found to be incompatible with proper safety precautions.

1/2" SECTION: SOUTH

PLATE NO.

5

OF 8

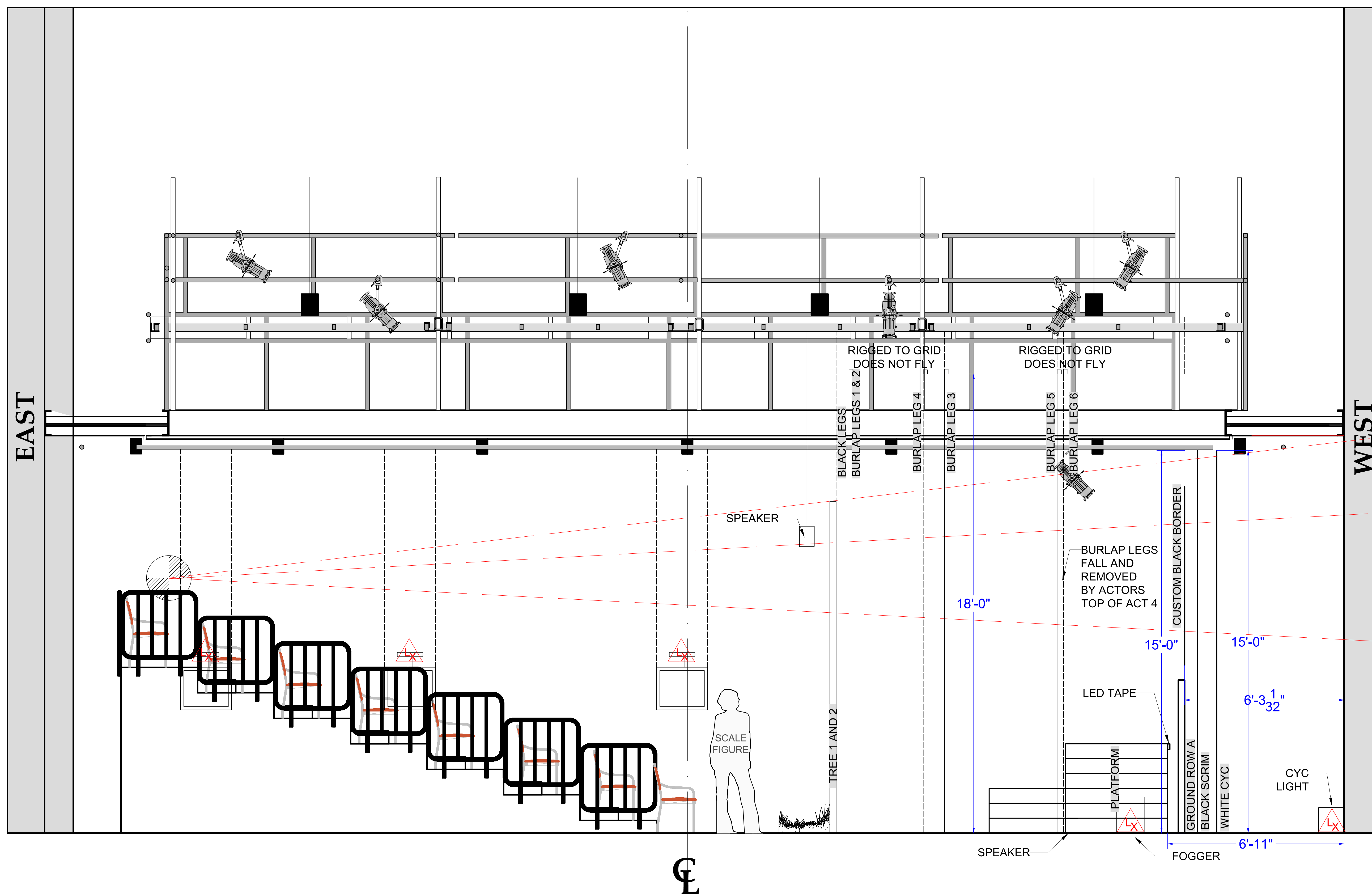



PRODUCTION TEAM:

DIRECTOR
KATIE BROOK
SCENIC DESIGNER
CECILIA SHIN
LIGHTING DESIGNER
XUEWEI HU
COSTUME DESIGNER
EMILY MARSHBURN
SOUND DESIGNER
EMILY BRUNNER
PRODUCTION MANAGER
MELISSA LUBINA
TECHNICAL DIRECTOR / JOB LEAD
OWEN SAHNOW

DATE: 02/03/2023

SCALE: AS INDICATED

REVISION NO: V5

DRAWN BY: C.S.

The designer is responsible for the visual aspects of the production only, and the specification of the designer's designs relate solely to the appearance of the design and not to matters of safety. The designer agrees to make prompt correcting alterations to any specifications found to be incompatible with proper safety precautions.

**TREES & BURLAP LEGS
DETAIL**

PLATE NO.

6

OF 8

NOTES:
-TREE 1 AND 2 HAVE BRUSHSTROKE TEXTURE CREATED WITH SCULPT AND COAT.
-BURLAP LEGS 1-6 ARE RIGGED TO THE GRID. THEY FALL AND ARE REMOVED FOR ACT 4 BY ACTORS
-HOOKS ON TREE 1 AND 2 ARE PAINTED MATTE BLACK.

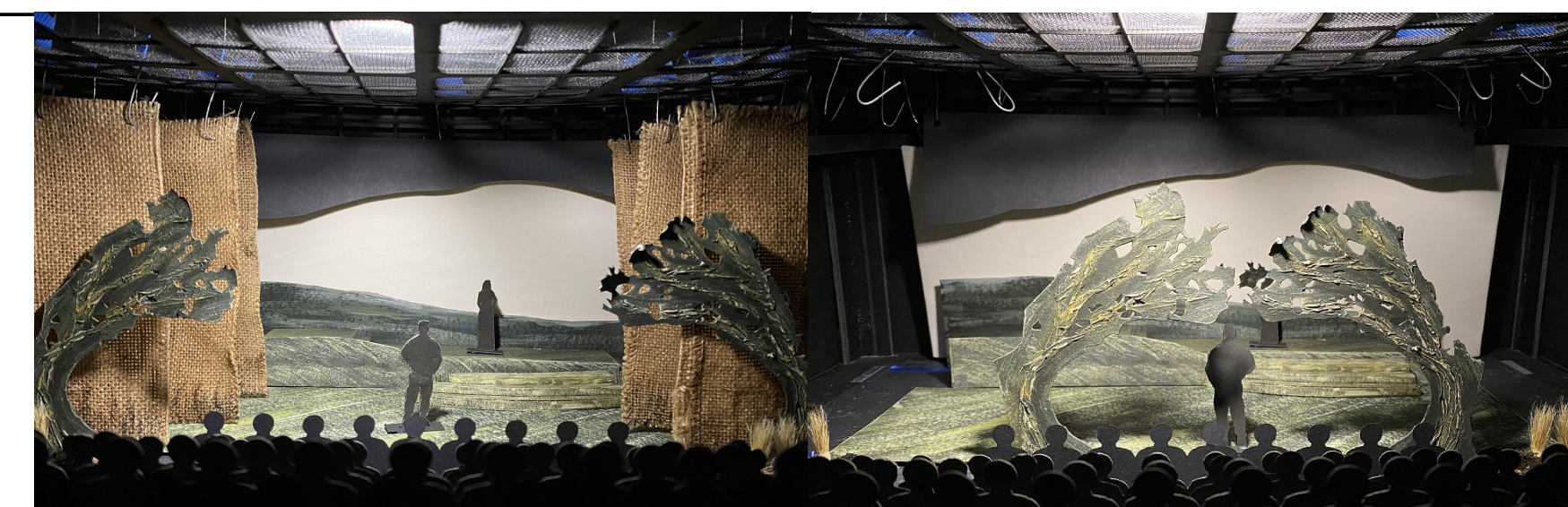

MODEL PHOTO: ACT 1-3
NOT TO SCALE

MODEL PHOTO: ACT 4
NOT TO SCALE

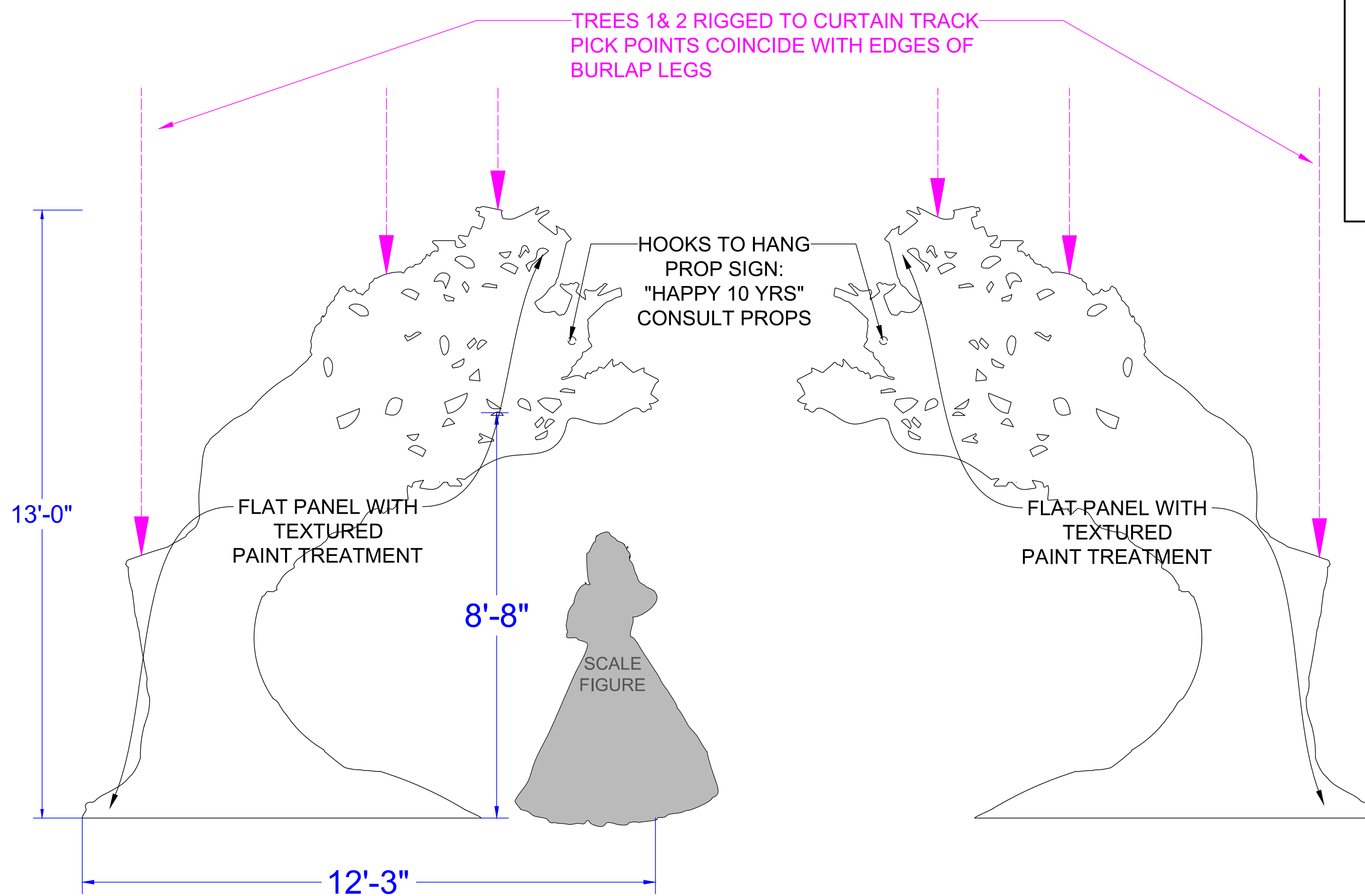

1 TREE 1 - FRONT VIEW
6 SCALE: 1/2" = 1'-0"

2 TREE 2 - FRONT VIEW
6 SCALE: 1/2" = 1'-0"

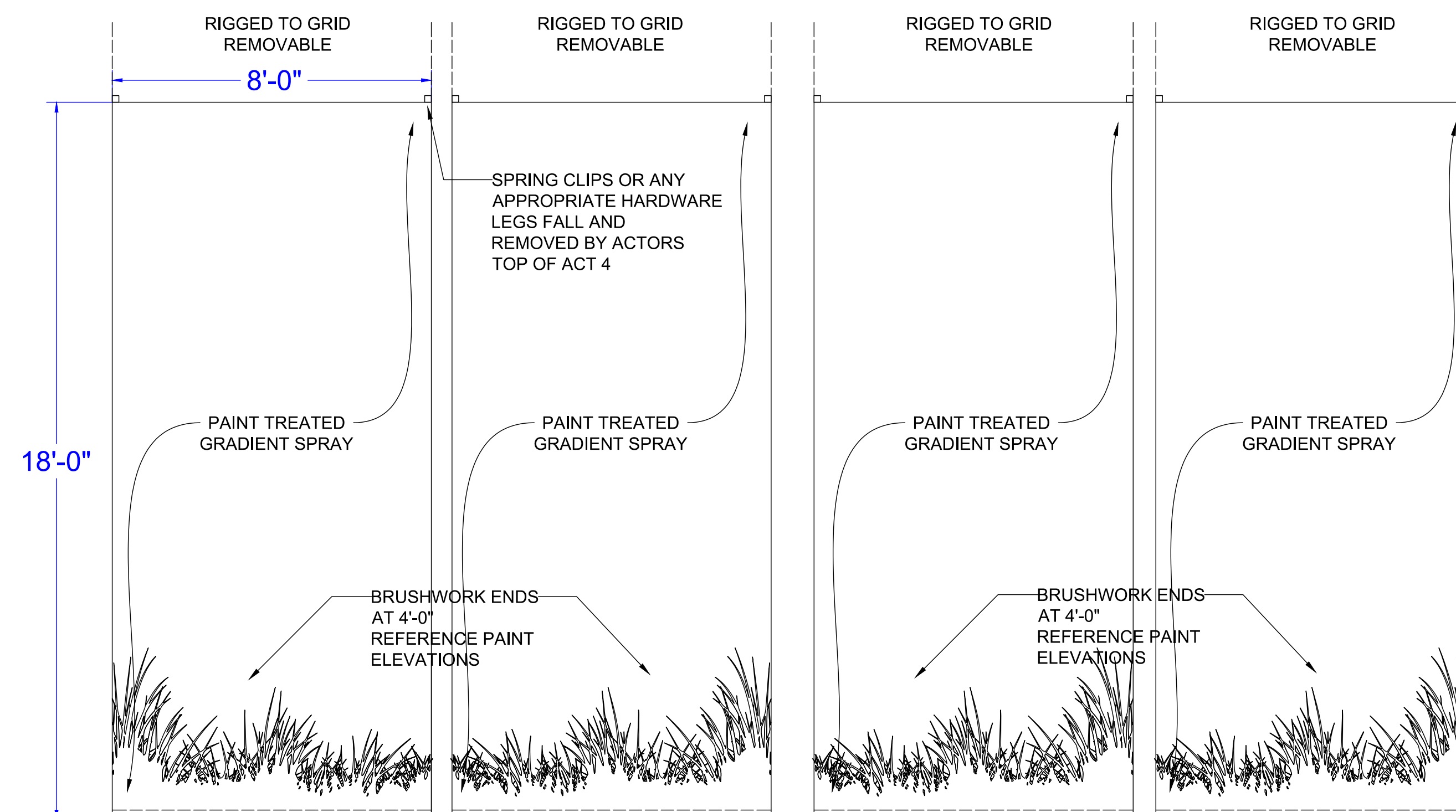

4 BURLAP LEGS 3 AND 4 - FRONT VIEW
6 SCALE: 3/8" = 1'-0"

5 BURLAP LEGS 5 AND 6 - FRONT VIEW
6 SCALE: 3/8" = 1'-0"

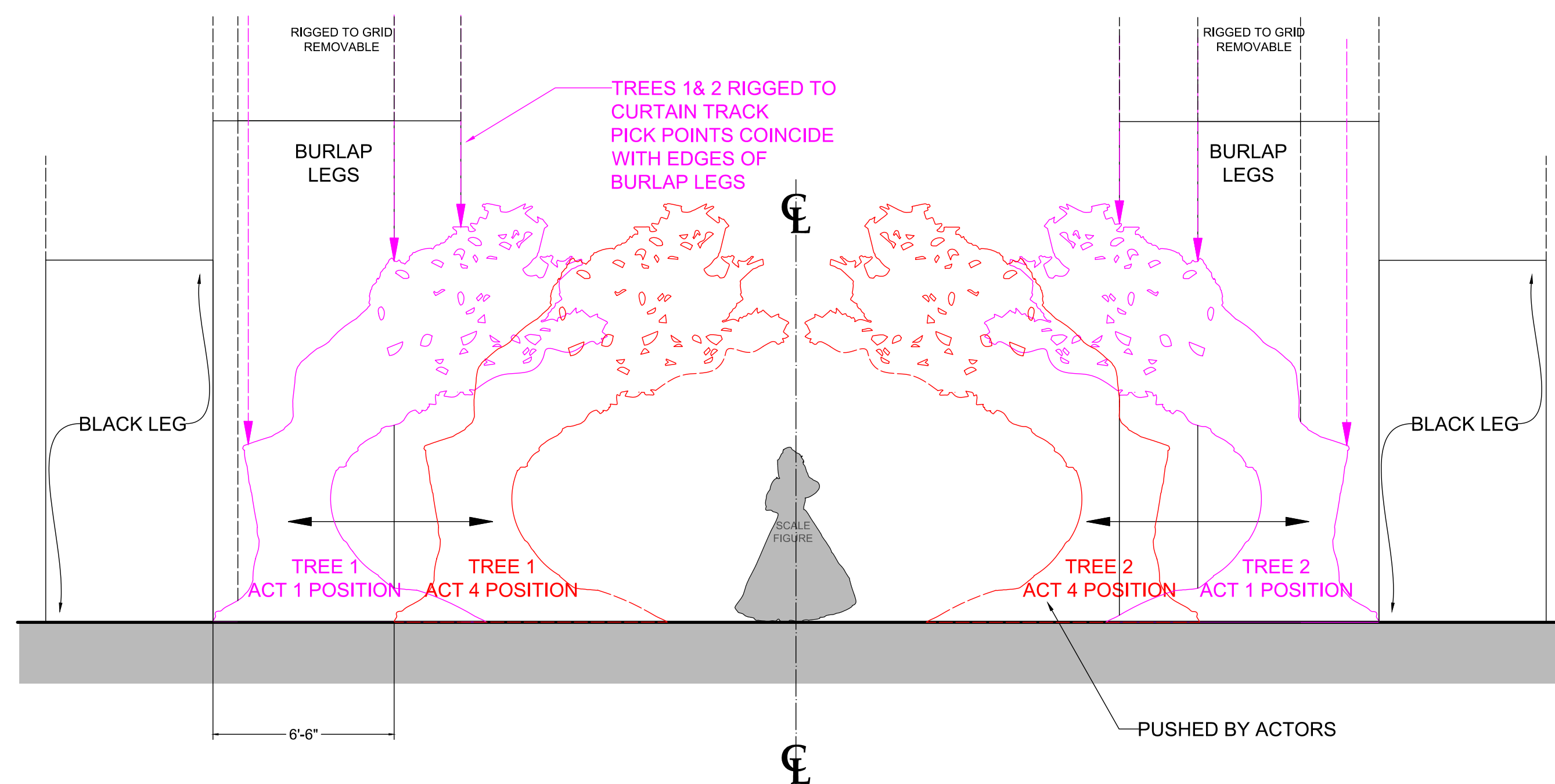

3 TREE 1 & 2 MOVEMENT - FRONT VIEW
6 SCALE: 1/4" = 1'-0"

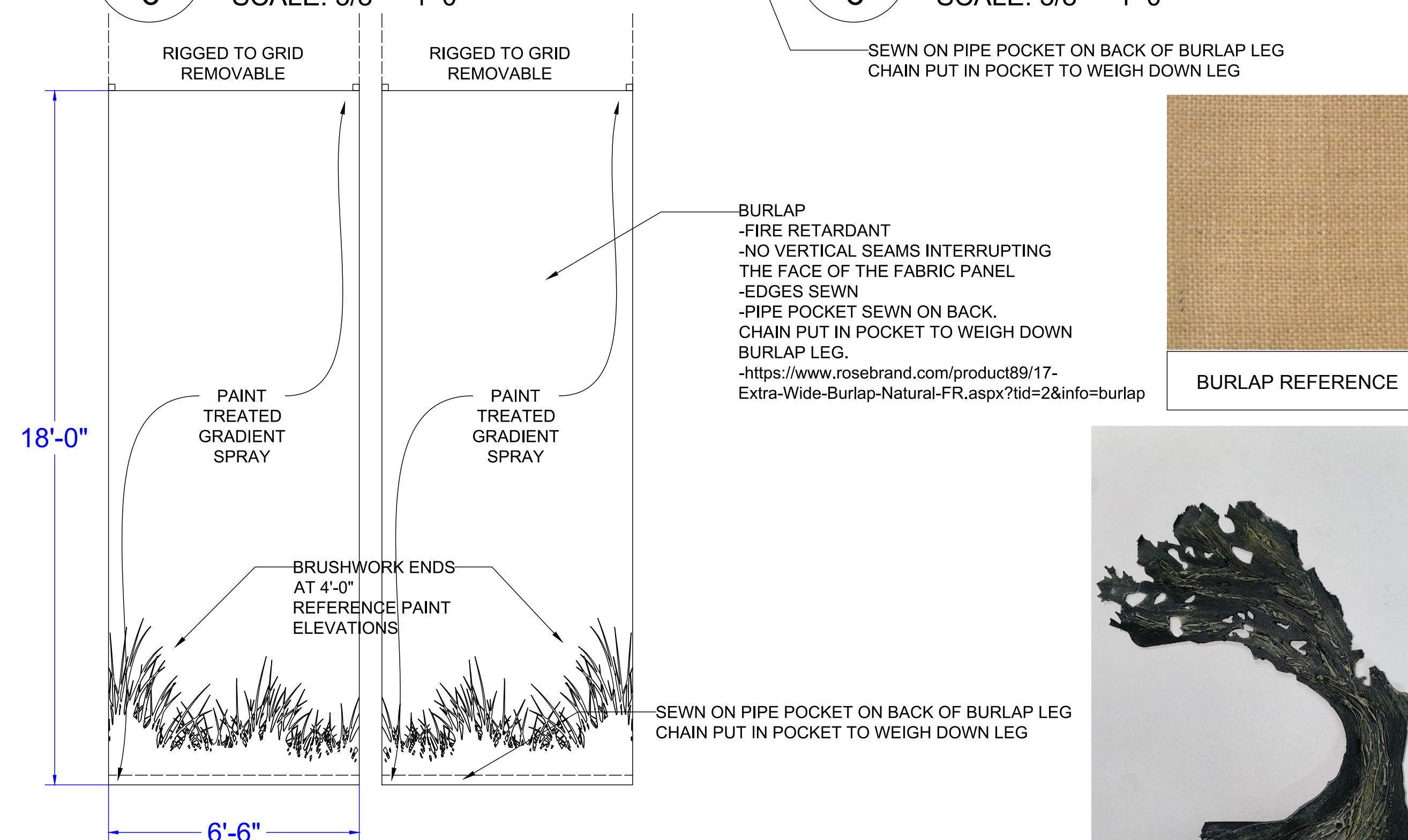

6 BURLAP LEGS 1 AND 2 - FRONT VIEW
6 SCALE: 3/8" = 1'-0"





PRODUCTION TEAM:

DIRECTOR
KATIE BROOK
SCENIC DESIGNER
CECILIA SHIN
LIGHTING DESIGNER
XUEWEI HU
COSTUME DESIGNER
EMILY MARSHBURN
SOUND DESIGNER
EMILY BRUNNER
PRODUCTION MANAGER
MELISSA LUBINA
TECHNICAL DIRECTOR / JOB LEAD
OWEN SAHNOW

DATE: 02/03/2023

SCALE: AS INDICATED

REVISION NO: V5

DRAWN BY: C.S.

The designer is responsible for the visual aspects of the production only, and the specification of the designer's designs relate solely to the appearance of the design and not to matters of safety. The designer agrees to make prompt correcting alterations to any specifications found to be incompatible with proper safety precautions.

GROUND ROWS

PLATE NO.

7

OF 8



FOLIAGE REFERENCE
NOT TO SCALE

NOTES:
-BACK OF PLATFORM LINED WITH LED TAPE
-FOLIAGE SR AND SL PADS CAN BE WALKED ON
-BOTH ESCAPE STAIRS RECEIVE TEXTURED DRY BRUSH PAINT TREATMENT

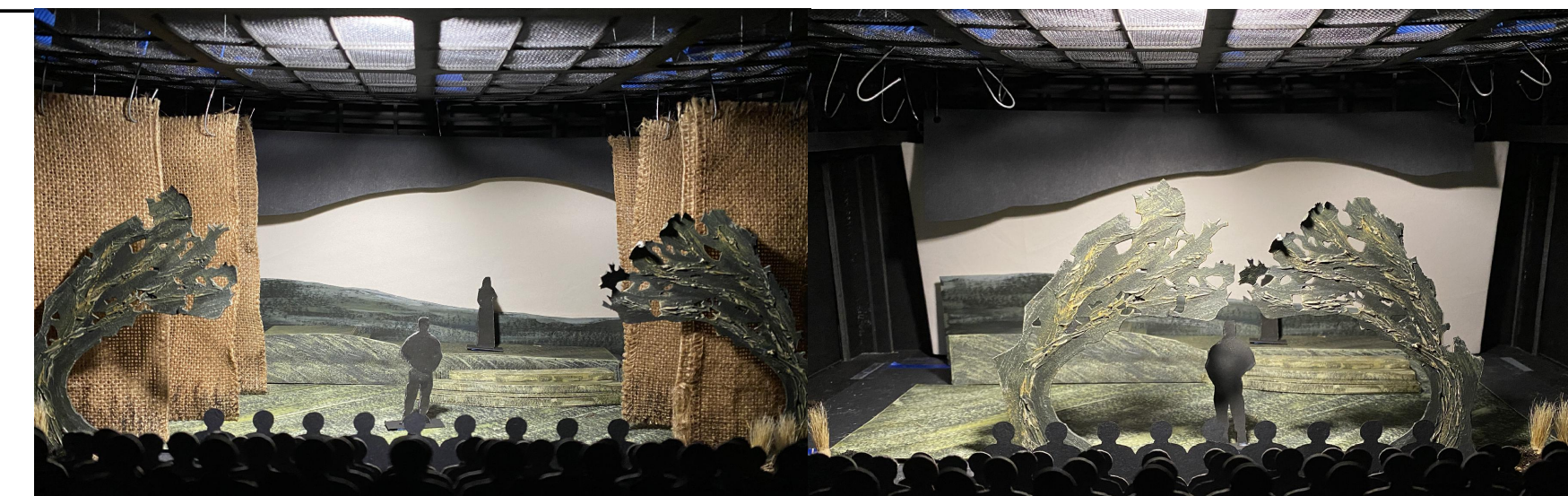

MODEL PHOTO: ACT 1-3
NOT TO SCALE

MODEL PHOTO: ACT 4
NOT TO SCALE

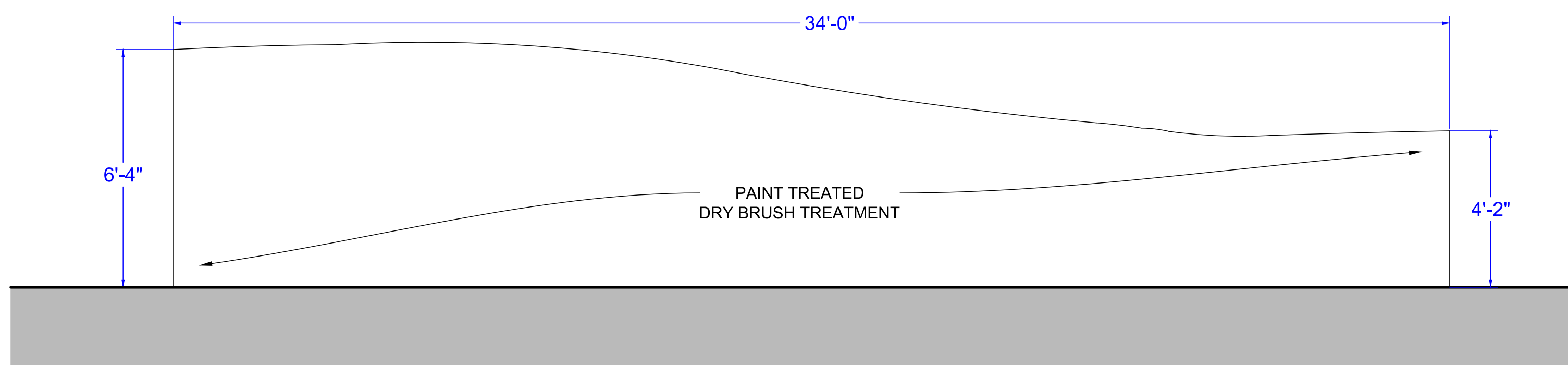

1 GROUND ROW A - FRONT VIEW
7 SCALE: 3/8" = 1'-0"

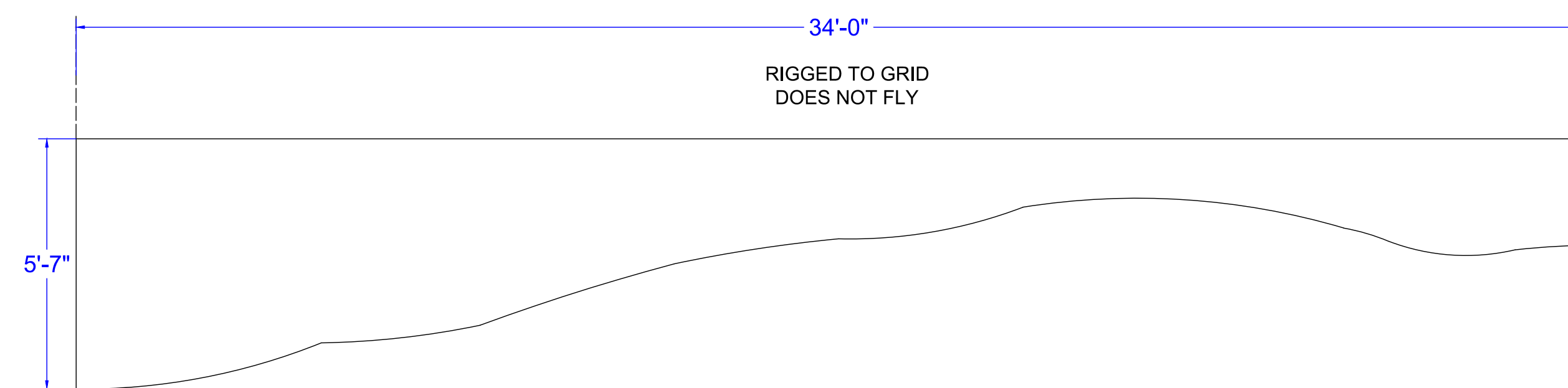

5 CUSTOM BLACK BORDER - FRONT VIEW
7 SCALE: 3/8" = 1'-0"

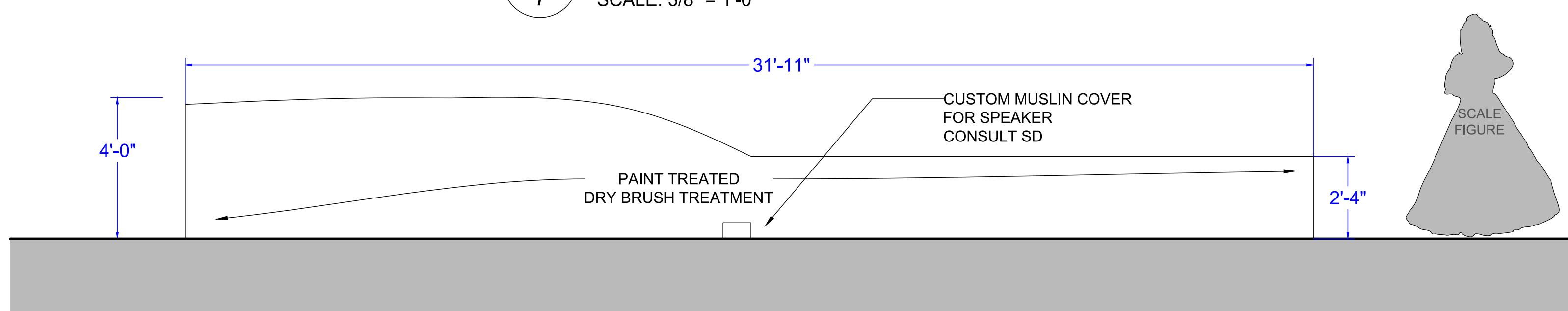

2 PLATFORM FACING - FRONT VIEW
7 SCALE: 3/8" = 1'-0"

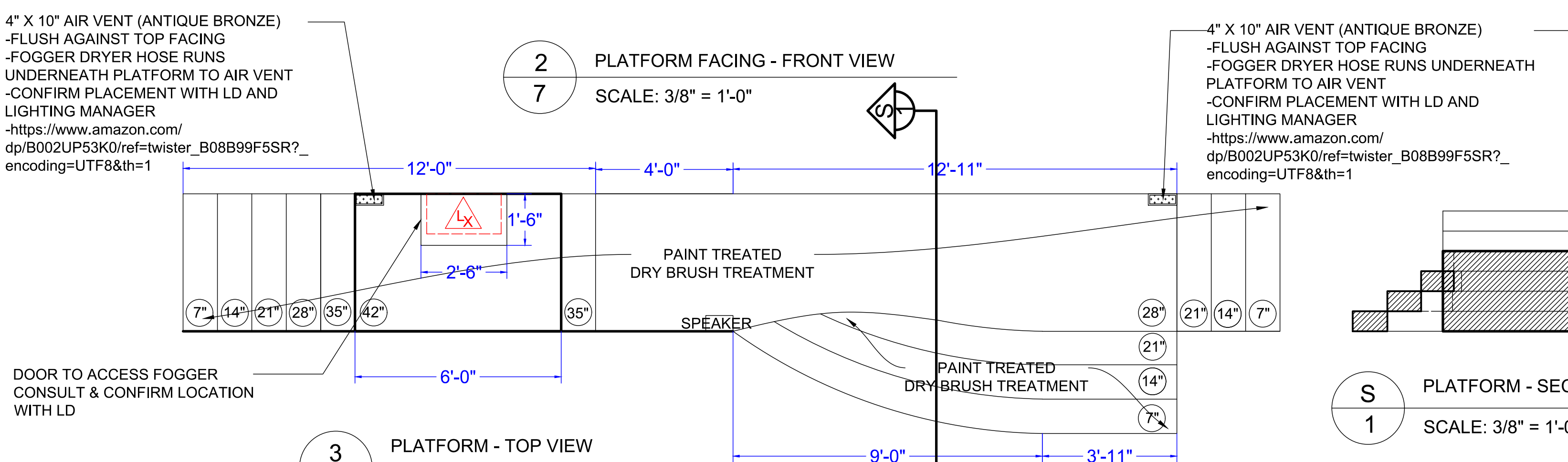

3 PLATFORM - TOP VIEW
7 SCALE: 3/8" = 1'-0"

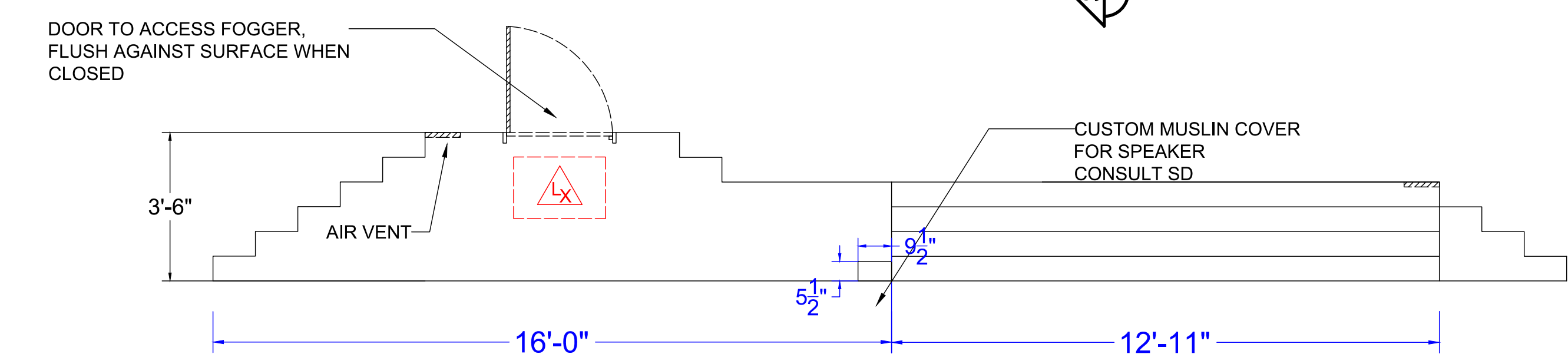

4 PLATFORM - FRONT VIEW
7 SCALE: 3/8" = 1'-0"

S PLATFORM - SECTION
1 SCALE: 3/8" = 1'-0"

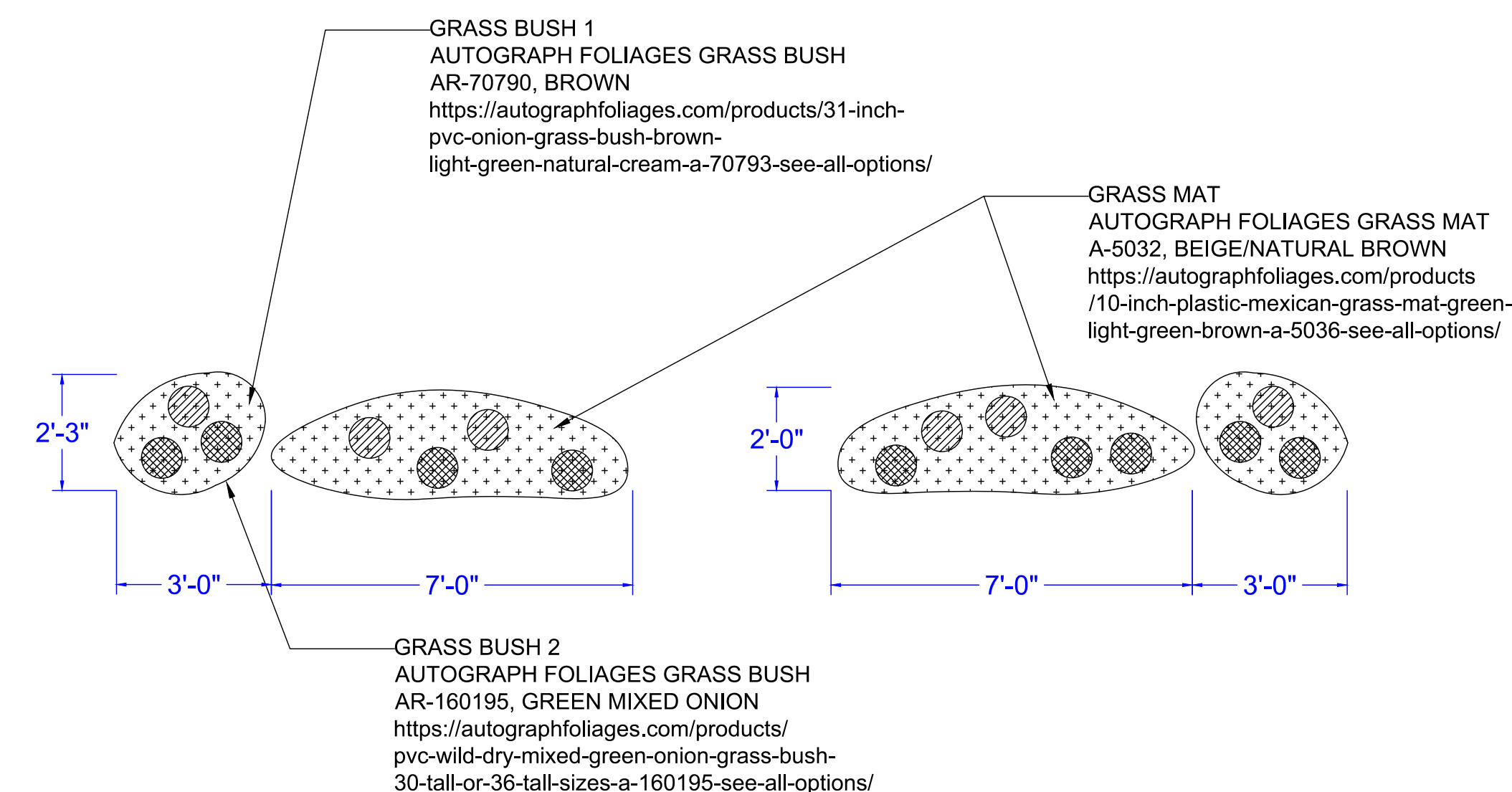

6 FOLIAGE SR PAD 1&2 - TOP VIEW
7 SCALE: 3/8" = 1'-0"

7 FOLIAGE SL PAD 1&2 - TOP VIEW
7 SCALE: 3/8" = 1'-0"



AR-70790
GRASS BUSH 1



AR-160195
GRASS BUSH 2



A-5032
GRASS MAT



PRODUCTION TEAM:
 DIRECTOR
 KATIE BROOK
 SCENIC DESIGNER
 CECILIA SHIN
 LIGHTING DESIGNER
 XUEWEI HU
 COSTUME DESIGNER
 EMILY MARSHBURN
 SOUND DESIGNER
 EMILY BRUNNER
 PRODUCTION MANAGER
 MELISSA LUBINA
 TECHNICAL DIRECTOR
 OWEN SAHNOW

DATE: 02/03/2023

SCALE: 1" = 1'-0"

REVISION NO: V5

DRAWN BY: C.S.

The designer is responsible for the visual aspects of the production only, and the specification of the designer's designs relate solely to the appearance of the design and not to matters of safety. The designer agrees to make prompt correcting alterations to any specifications found to be incompatible with proper safety precautions.

MUSEUM FRAMES

PLATE NO.

8

OF 8



MUSEUM FRAME REFERENCE (NOT TO SCALE)



MODEL PHOTO: ACT 1-3 NOT TO SCALE



MODEL PHOTO: ACT 4 NOT TO SCALE

NOTES:
 -6X MUSEUM FRAMES

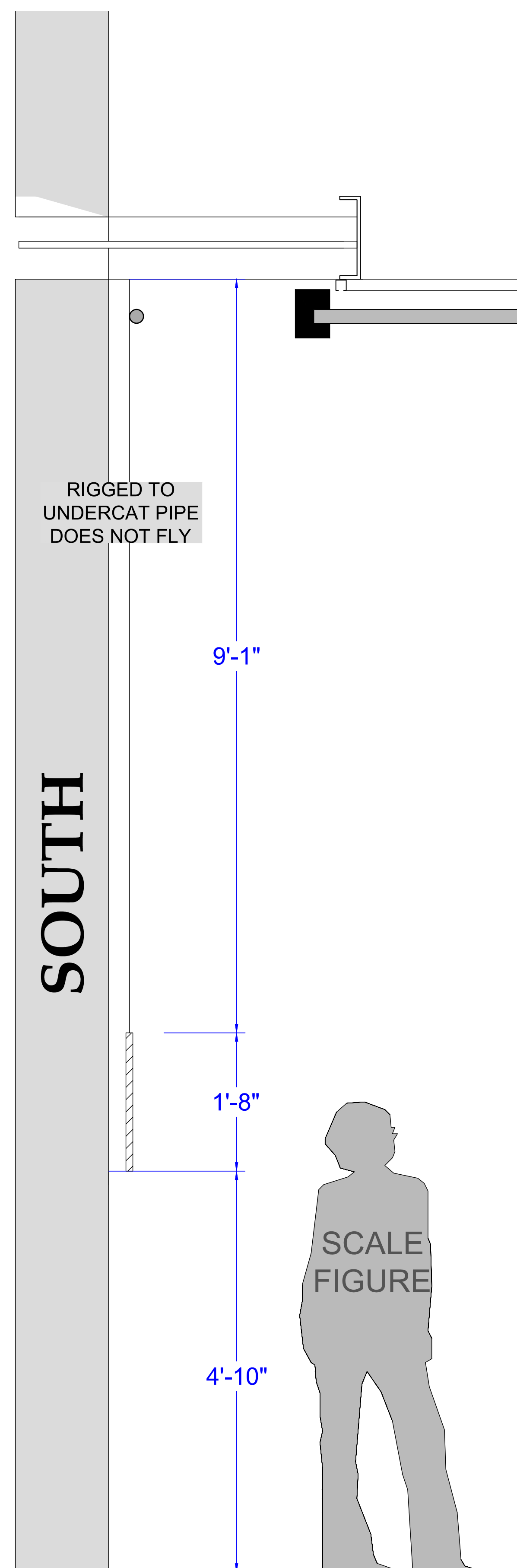

2 MUSEUM FRAMES - RIGGED
 8 SCALE: 1" = 1'-0"

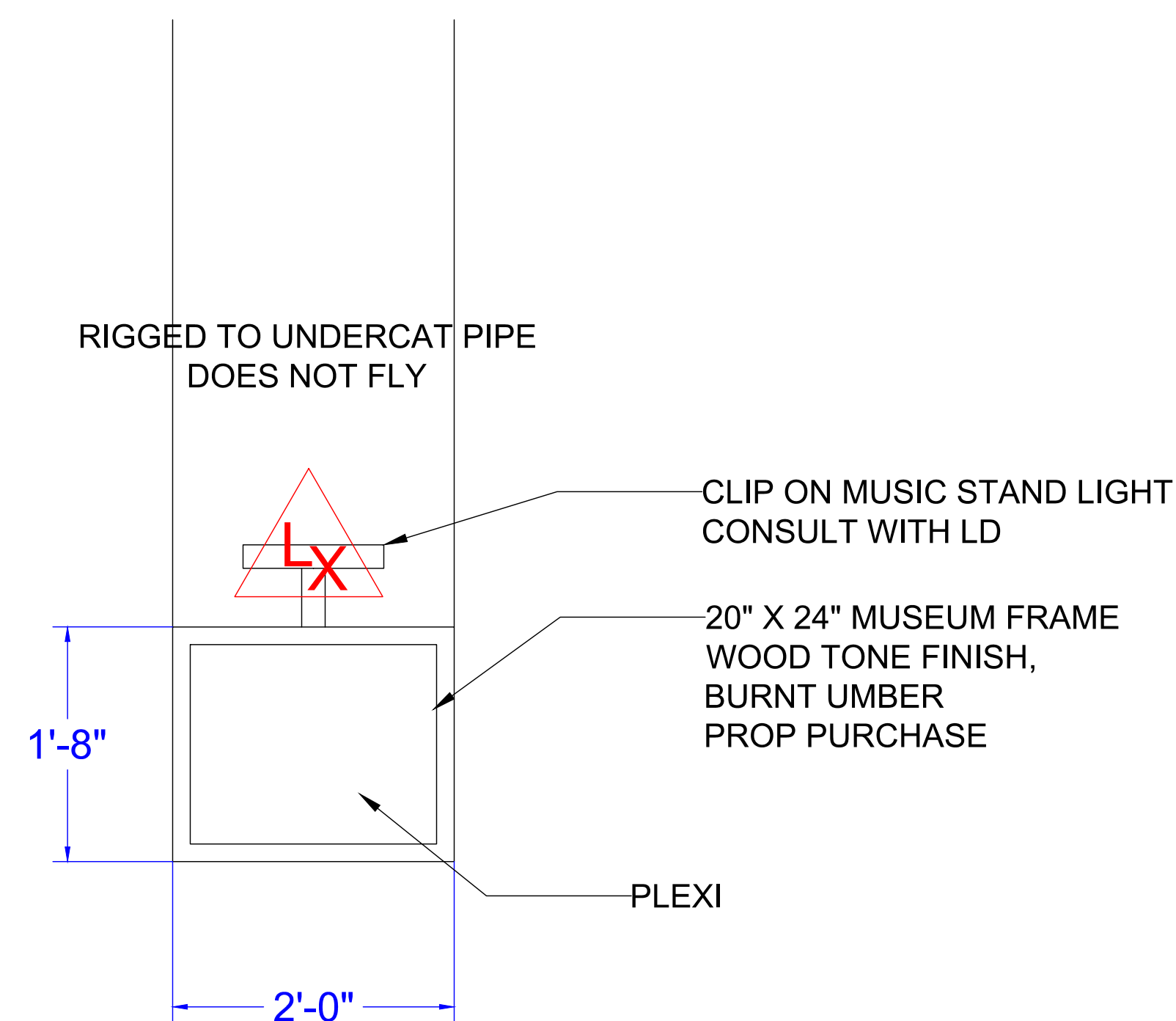

1 MUSEUM FRAMES - FRONT VIEW
 8 SCALE: 1" = 1'-0"